



ООО «Новые Сети»
Проектирование сетей, поставка оборудования,
оптимизация и поддержка ИТ-инфраструктуры.
<https://newnets.ru>

FEATURES

- -40°C to +85°C operating case temperature
- SFP28 package with duplex LC receptacle connector
- Hot-pluggable capability
- Single 3.3V power supply
- MWDM cooled DFB transmitter and high performance PIN or APD receiver
- Up to 10km transmission distance over SMF
- Maximum power consumption 2W
- OAM function integrated
- SFI electrical interface
- Low EMI and excellent ESD protection
- Built-in Digital Diagnostic Monitoring (DDM) function
- Class I laser safety standard IEC-60825 compliant
- RoHS-6 compliance

APPLICATIONS

- Ethernet
- eCPRI

STANDARDS

- Complies with SFP28 MSA (SFF-8402)
- Complies with SFF-8432
- Complies with SFF-8419
- Complies with SFF-8472
- Complies with SFF-8024
- Complies with Open WDM standard of China Mobile

Центральный офис в Москве:
Тел: +7 (499) 346 00 00

E-mail: info@newnets.ru

Филиал в Новосибирске:
Тел: +7 (383) 376 66 75 -



NETS

ООО «Новые Сети»
 Проектирование сетей, поставка оборудования,
 оптимизация и поддержка ИТ-инфраструктуры.
<https://newnets.ru>

ABSOLUTE MAXIMUM RATING						
Parameter	Symbol	Min.	Typ	Max.	Unit	Notes
Storage Ambient Temperature	T _{STG}	-40		85	°C	
Relative Humidity	OH	5		85	%	
Power Supply Voltage	V _{CC}	-0.3		3.6	V	
ESD sensitivity		-500		500	V	High speed pins
		-2K		2K	V	others
Receiver Damage Threshold		6			dBm	PIN
		-2.5			dBm	APD

RECOMMENDED OPERATING CONDITION						
Parameter	Symbol	Min.	Typ.	Max.	Unit	Notes
Operating Case Temperature	T _c	-40		85	°C	
Operating Humidity	OH	5		85	%	
Power Supply Voltage	V _{CC}	3.13	3.3	3.46	V	
Power Supply Consumption	P			2	W	
Data Rate		24.33	25.78		Gbps	CDR Enable
Link Distance		10			km	Single Mode Fiber (SMF)

TRANSMITTER OPTICAL CHARACTERISTICS						
Parameter	Symbol	Min.	Typ.	Max.	Unit	Notes
Center wavelength		1272	1274.5	1277	nm	
		1292	1294.5	1297		
		1312	1314.5	1317		
		1332	1334.5	1337		
		1352	1354.5	1357		
		1372	1374.5	1377		
Side Mode Suppression Mode	SMSR	30			dB	
Average Launch Power(EOL)	P _{OUT}	2		6	dBm	Launched into SMF Fiber
Optical Modulation Amplitude	OMA	1		6	dBm	
Transmitter and dispersion penalty(TDP)	TDP			1	dB	1265nm~1317nm
				3	dB	1325nm~1337nm
				4.5	dB	1345nm~1377nm
Optical Power for TX DISABLE	P _{TX-DIS}			-30	dBm	
Extinction Ratio	ER	3.5			dB	
RIN _{20OMA}				-130	dB/Hz	



Optical return loss tolerance				20	dB	
Transmitter reflectance				-26	dB	Note1
Optical Eye Mask Margin		5			%	
Transmitter eye mask definition {X1, X2, X3, Y1, Y2, Y3}		{0.31, 0.4, 0.45, 0.34, 0.38, 0.4}				Eye mask hit ratio is 5E-5

Note1: Transmitter reflectance is defined looking into the transmitter

RECEIVER OPTICAL CHARACTERISTICS						
Parameter	Symbol	Min.	Typ.	Max.	Unit	Notes
Operating Wavelength	λ_c	1260		1610	nm	
Receiver Sensitivity(AVG) @BER \leq 5E-5	SEN(AVG)			-13	dBm	PIN receiver
				-18		APD receiver
Receiver Sensitivity(OMA) @BER \leq 5E-5	SEN(OMA)			-14	dBm	PIN receiver
				-19		APD receiver
Saturation Optical Power(AVG)	SAT(AVG)			2	dBm	PIN receiver
				-4		APD receiver
LOS De-Assert	LOS _D			-17	dBm	PIN receiver; PRBS2 ³¹ -1@25.78Gbps
				-22		APD receiver; PRBS2 ³¹ -1@25.78Gbps
LOS Assert	LOS _A	-30			dBm	PRBS2 ³¹ -1@25.78Gbps
LOS Hysteresis	HYS	0.5			dB	PRBS2 ³¹ -1@25.78Gbps
Receiver reflectance				-26	dB	

OAM CHARACTERISTICS						
Parameter	Symbol	Min.	Typ.	Max.	Unit	Notes
OAM Data Rate		994	1024	1054	bps	Manchester Code
OAM Modulated Deep	Md	3%		5%		Note2
OAM Receiver Sensitivity @BER \leq 1E-8 (Note3)				-19	dBm	PIN receiver
				-24		APD receiver

Note2: Modulated deep definition complies with Open WDM standard
 Note3: OAM frame structure complies with Open WDM standard

ELECTRICAL CHARACTERISTICS						
Parameter	Symbol	Min.	Typ.	Max.	Unit	Notes
Input or Output Differential Impedance		90	100	110	Ω	
Differential input eye height from host	TX_EH	100		900	mV _{PPD}	
Differential data output swing	Vout	300		800	mV	



NETS

ООО «Новые Сети»
Проектирование сетей, поставка оборудования,
оптимизация и поддержка ИТ-инфраструктуры.
<https://newnets.ru>

TX Disable, RS0, RS1	VIH	2		VCC+0.3	V	
	VIL	-0.3		0.8	V	
TX Fault, RX LOS	VOH	2.4		VCC _{HOST}	V	
	VOL	-0.3		0.4	V	

PIN DESCRIPTION			
PIN	Name	Description	Notes
1	V _{EE} T	Transmitter Ground	
2	TX_Fault	Transmitter Fault Indication	Low: normal; High: abnormal
3	TX_Disable	Transmitter Disable	Low: transmitter on; High: transmitter off
4	SDA	SDA	The data line of two wire serial interface
5	SCL	SCL	The clock line of two wire serial interface
6	MOD_ABS	Module Absent	Connected to V _{EE} T or V _{EE} R in the module
7	RS0	Receiver Rate Select	
8	RX_LOS	Loss of Signal	Low: signal detected; High: loss of signal
9	RS1	Transmitter Rate Select	
10	V _{EE} R	Receiver Ground	
11	V _{EE} R	Receiver Ground	
12	RD-	Inv. Received Data Out	AC-coupled, CML
13	RD+	Received Data Out	AC-coupled, CML
14	V _{EE} R	Receiver Ground	
15	V _{CC} R	Receiver Power	
16	V _{CC} T	Transmitter Power	
17	V _{EE} T	Transmitter Ground	
18	TD+	Transmit Data In	AC-coupled, CML
19	TD-	Inv. Transmit Data In	AC-coupled, CML
20	V _{EE} T	Transmitter Ground	



NETS

ООО «Новые Сети»
 Проектирование сетей, поставка оборудования,
 оптимизация и поддержка ИТ-инфраструктуры.
<https://newnets.ru>

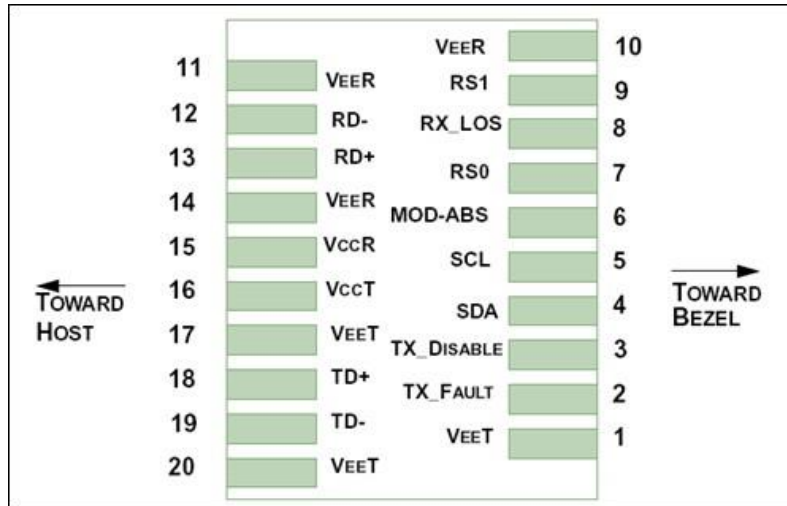

Figure 1 Pin Out Drawing (Top view)

TYPICAL INTERFACE CIRCUIT

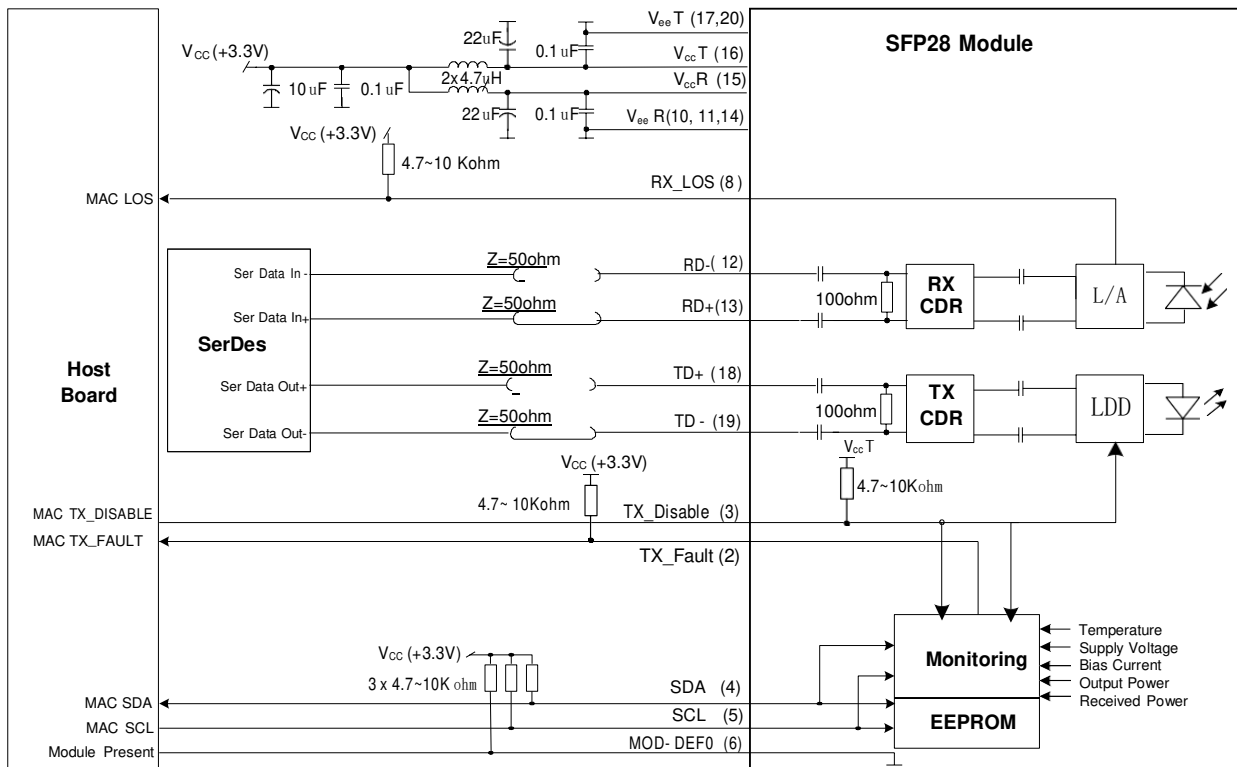

Figure 2 Typical Interface Circuit



NETS

ООО «Новые Сети»
 Проектирование сетей, поставка оборудования,
 оптимизация и поддержка IT-инфраструктуры.
<https://newnets.ru>

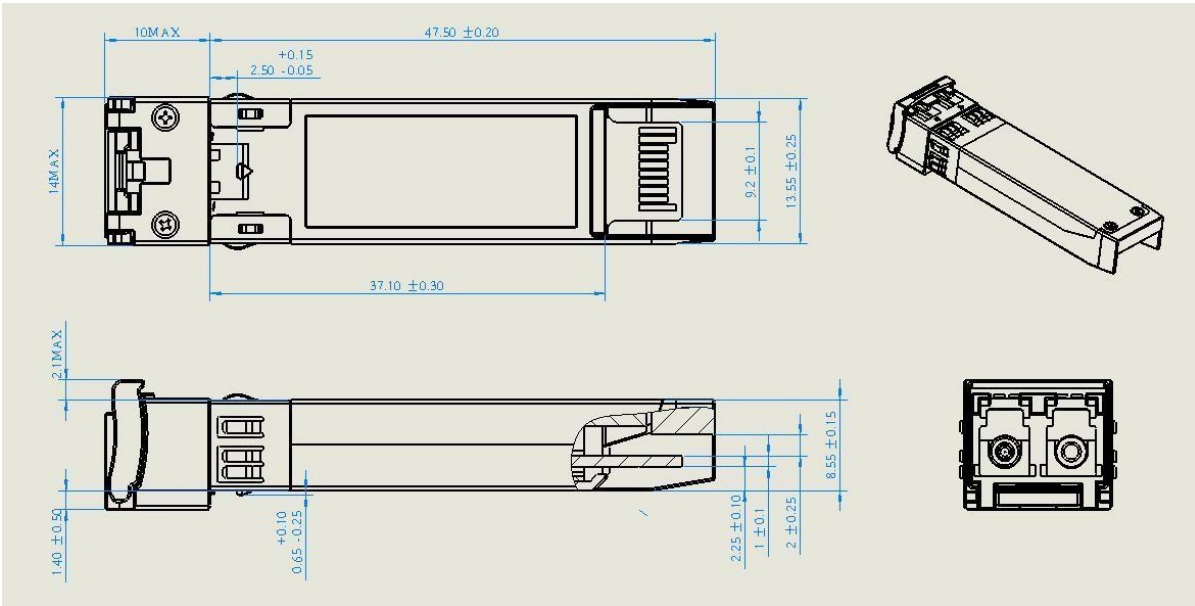

Figure 3 Package Outline

EEPROM INFORMATION

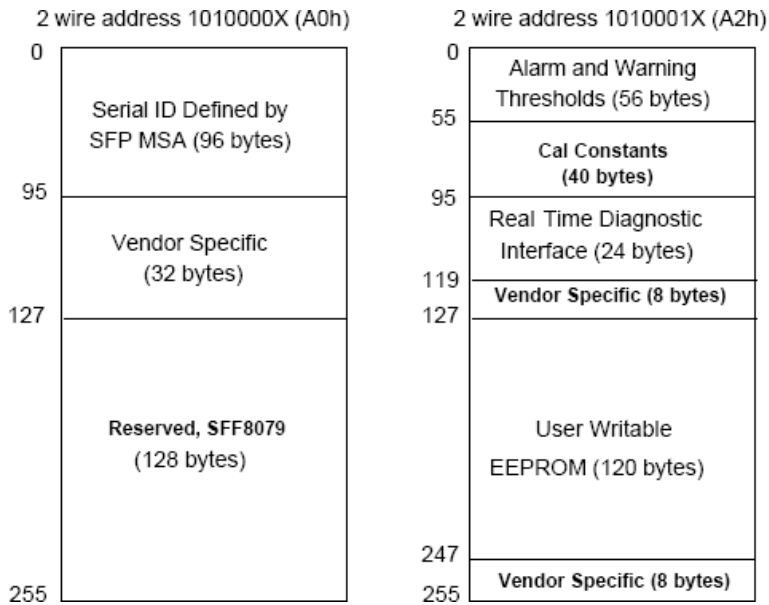

Figure 4 EEPROM Memory Map Specific Data Field Descriptions



DIGITAL DIAGNOSTIC MONITORING INTERFACE

Parameter	Range	Accuracy	Calibration	NOTES
Temperature	-20 to 85°C	±3°C	Internal	LSB: 1/256C
Voltage	2.97 to 3.63V	±3%	Internal	LSB: 0.1mV
Bias Current	0 to 120mA	±10%	Internal	LSB: 2uA
TX Power	1 to 7dBm	±2dB	Internal	LSB: 0.1uW
RX Power(PIN Receiver)	-17 to 3dBm	±2dB	Internal	LSB: 0.1uW
RX Power(APD Receiver)	-18.5 to -2.5dBm	±2dB	Internal	LSB: 0.1uW

WARNINGS

- Handling Precautions: This device is susceptible to damage as a result of electrostatic discharge (ESD). A static free environment is highly recommended. Follow guidelines according to proper ESD procedures.
- Laser Safety: Radiation emitted by laser devices can be dangerous to human eyes. Avoid eye exposure to direct or indirect radiation.

LEGAL NOTES

- All information contained in this document is subject to change without notice, at our company' s sole and absolute discretion. Our company warrants performance of its products to current specifications only in accordance with the company' s standard one-year warranty; however, specifications designated as "preliminary" are given to describe components only, and Our compay expressly disclaims any and all warranties for said products, including express, implied, and statutory warranties, warranties of merchantability, fitness for a particular purpose, and non-infringement of proprietary rights. Please refer to the company' s Terms and Conditions of Sale for further warranty information.
- Our company assumes no liability for applications assistance, customer product design, software performance, or infringement of patents, services, or intellectual property described herein. No license, either express or implied, is granted under any patent right, copyright, or intellectual property right, and Our company makes no representations or warranties that the product(s) described herein are free from patent, copyright, or intellectual property rights. Products described in this document are NOT intended for use in implantation or other life support applications where malfunction may result in injury or death to persons. Our company customers using or sellingproducts for use in such applications do so at their own risk and agree to fully defend and indemnify Our company for any damages resulting from such use or sale.
THE INFORMATION CONTAINED IN THIS DOCUMENT IS PROVIDED ON AN "AS IS" BASIS. Customer agrees that Our company is not liable for any actual, consequential, exemplary, or other damages arising directly or indirectly from any use of the information contained in this document. Customer must contact usto obtain the latest version of this publication to verify, before placing any order, that the information contained herein is current. All rights reserved.